

# MINI-SKIMMERS™

The Best Coolant Oil Skimmers since 1989!



## Choice of three belt materials for any application! Tiny – fits anywhere!



Made In the U.S.A.

**MINI-SKIMMERS™** have been sold worldwide since 1989 and come in five standard, stocked (same day shipping!) models with three different belt types. ALL **Mini-Skimmers™** include:

- Hobbed steel gears for the ultimate in durability.
- Permanent magnet synchronous motors for the highest level of precision.
- Extruded pinion which conforms to AGMA7 level quality- built right where it counts.
- Liquid resistant design for the environments these skimmers need.
- Belt technology proven over 35 years of service.
- Old School Product & Technical Support.



MSB-A & ECB



MSB-B



DBS

All **Mini-Skimmers™** fit onto the Mini-Sep™ gravity separator!

**Mini-Skimmers™** use a 115/1/60 motor but are available in 220V 50 or 60Hz & 12/24 VDC. Flat poly belts can be made for up to 20' reaches!

**Models MSB-A & ECB** use our fiberglass-reinforced, cogged polyurethane belts – the **Mini-Skimmer™** original! MSB-A w/timer, hose, inline GFCI (NEW!).

**Model MSB-B** uses our stainless steel belts, perfect for harsh or caustic environments.

**Model DBS** uses our economy belts – same proven motor and collection rate.

**SKINNI-MINI™**, or Model SMB, comes with a cogged poly belt and a tail pulley that fits into a 2" bung hole – perfect for skimming storage drums, reducing transportation and storage costs.

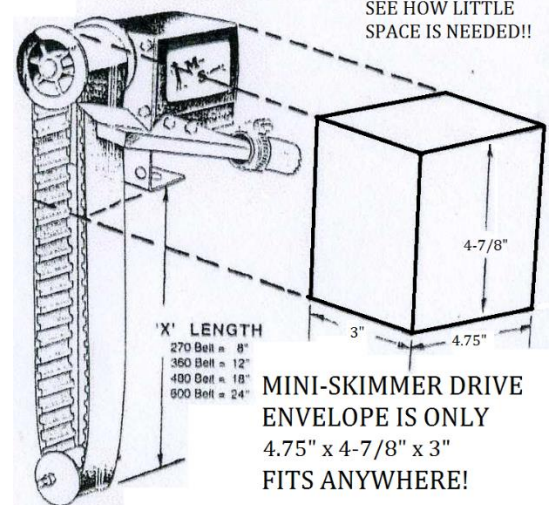

MOST **RELIABLE, LONGEST-LASTING** ON THE MARKET!!  
TAIL PULLEY COMES WITH STABILIZER BAR!  
ONE YEAR MANUFACTURING WARRANTY!  
**SAME DAY SHIPPING!!**

# WAYNE PRODUCTS